



# MARATHWADA MITRA MANDAL'S COLLEGE OF COMMERCE

Affiliated to Savitribai Phule Pune University,  
Re-Accredited by NAAC with "A" Grade

## REPORT ON TWO DAY WORKSHOP ON ENTREPRENEURIAL SKILL DEVELOPMENT

**Date:14/05/2022**

Department of Business Administration had organized a two-day workshop on 12<sup>th</sup> and 13<sup>th</sup> May, 2022 on "Entrepreneurial Skill Development". 55 students attended the workshop along with all the faculties.

Day 1 of the workshop started on 12<sup>th</sup> May, 2022 with the inaugural session. The inaugural session was wonderfully and smoothly conducted with the cooperation of all the faculties and student coordinators present for the event. The Resource Person and Chief Guest for the event was Dr. Manisha Jagtap. She shared her knowledge and expertise in the field of Entrepreneurship through a wonderful and informative presentation which consisted of various perspectives and information on entrepreneurship, who is an entrepreneur, what is a start-up, the type of schemes provided by the Government in developing and helping start-ups in the state and the various subsidies provided by each scheme.

Day 2 of the workshop was held on 13<sup>th</sup> May, 2022. The session was conducted by Mr. Sachin Parekh where he mentioned 10 different characteristics of an entrepreneur. Presentation was given on trust, risk-taking and entrepreneurship culture. The presentation was followed by a team-building exercise that all the students had to participate in to develop practical and application knowledge. The activity was followed by a Q&A session where the students were able to get their doubts cleared which led to the session being much more efficient and effective. The Q&A session was followed by the feedback on the session and then the vote of thanks which marked the end of the workshop.

Dr. Ashwini Kulkarni  
HOD

Dr. Devidas Golhar  
Principal





# MARATHWADA MITRA MANDAL'S COLLEGE OF COMMERCE

Affiliated to Savitribai Phule Pune University,  
Re-Accredited by NAAC with "A" Grade

## REPORT ON ONE DAY WORKSHOP ON IMPORTANCE OF IPR FOR START UPS

**Date:11/06/2023**

One-day workshop on "Importance of IPR for Start Ups" was conducted by Department of Business Administration on 10<sup>th</sup> June, 2023. Total 50 students attended the session. All the faculties graced the occasion with their presence.

The program commenced with the introduction of the day's resource person, Adv. Smita Koppal. Asst. Prof. Snehal Borkar delivered the welcome address, following which Adv. Smita Koppal proceeded with the session.

The workshop aimed to educate students about startup entrepreneurs and the significance of protecting their intellectual property assets and leveraging them to foster innovation, growth, and competitiveness in the market.

The workshop commenced with an overview of intellectual property rights and their importance for startups. Students were introduced to the various forms of intellectual property, including patents, trademarks, copyrights, and trade secrets. Case studies and examples were presented to illustrate how startups can protect their inventions, brands, creative works, and confidential information.

The workshop wrapped up with a question and answer session during which students had the opportunity to address their queries. Prof. Gurmeet Kaur Rajpal delivered a vote of thanks, marking the conclusion of the workshop.

Dr. Ashwini Kulkarni  
HOD

Dr. Devidas Golhar  
Principal



### Service Agreement

This **Service Agreement** (hereinafter referred to as the "Agreement") is executed at Hyderabad, Telangana on DD-MON-YYYY (hereinafter "**the Effective Date**") by & between -

Mouktik Consulting Services Pvt. Ltd., having its registered office at Plot no. 8, Road no. 1, New Gayatri Nagar, Jilalguda, Telangana - 500 097, hereinafter referred as the "**COMPANY**", which expression shall unless repugnant to the context mean and include his/ their/its successors-in-interest, representatives, nominees, executors, administrators and assigns through its Authorised Signatory, Director, Mr. Nivarthi Srikanth

**AND**

**MARATHWADA MITRA MANDAL College OF COMMERCE, # 202/A, Deccan Gymkhana, Pune - 411004, MS.** hereinafter referred as the "**INSTITUTION**", which expression shall unless repugnant to the context to mean and include his/their/its successors-in-interest, representatives, nominees, executors, administrations, permitted assigns, subsidiaries, affiliates, and their successors and assigns through its Authorised Signatory, the **The Principal, Dr. DEVIDAS GOLHAR**

The **COMPANY** and the **INSTITUTION** are collectively referred to as the "Parties" and individually referred to as a "Party".

**NOW THEREFORE**, in consideration of the proposals submitted by the **COMPANY**, discussions, promises, undertaking herein contained and other good and valuable consideration, the receipt and sufficiency of which is hereby acknowledged, the Parties agree as follows:

#### 1. Program Summary

<b>Project</b>	<p>i. NASSCOM Foundation, has taken the overall responsibility of implementing a project titled, "Skilling Digitally Excellent Communities" which is a CSR project supported by BAJAJ for creating a skilled workforce by imparting industry relevant skills to 2000 youth on Digital 101 course, where 1000 beneficiaries will be given domain specific skills from economically weaker sections *, with a focus on women and helping 650 trained beneficiaries to get meaningful employment.</p> <p>ii. Mouktik Consulting Services Private Limited has expressed its interest to mobilize and train 2000 beneficiaries on Digital 101 course and train 1000 beneficiaries in entry level job courses with necessary focus on employability skills from economically weaker sections (as per the regional indicators for EWS /annual family income &lt; 8 lacs p.a.) who are in their Graduate / Polytechnic/Diploma, placement assistance for all beneficiaries and ensuring placement for at least 60% of beneficiaries in meaningful employment in the identified project geographies</p> <p>iii. NASSCOM Foundation has accepted the proposal submitted by Mouktik Consulting Services Private Limited and has agreed to award</p>
----------------	--





	<p>this service contract to Mouktik Consulting Services Private Limited. Mouktik Consulting Services Private Limited has agreed to undertake the services as outlined in this Agreement, in a timely and efficient manner, subject to and in accordance with the terms and conditions set out in this Agreement.</p>
Project Objective	To inspire and support young engineering students by providing them with trainings, online mentoring & resources that cover the core skills they need to get ready for work
Thematic Area	Skill Development under IT/ITES sector
Project Commencement Date	<<01-03-2023>>
Training Delivery Mode	Physical / Virtual / Platform domain

**Scope of work:**

INSTITUTION shall

- a. Enroll and facilitate certification on the Future skills Prime (FSP) portal in Digital 101 certification for ### candidates
- b. Register### candidates, also called the beneficiaries, pursuing Post Graduation /Graduation/Polytechnic/Diploma or graduate holders as per the master data template provided by the COMPANY for Skilling Digitally Excellent Communities (SDXC) program – Refer to annexure-1
- c. Appoint SPOC to
  - o Facilitate/coordinate all the training activities with the COMPANY
  - o Ensure candidates comply with the COMPANY instructions
- d. Provide infrastructure and other necessities in the college premises for conducting classroom trainings
- e. Ensure 80% attendance for the program in both ILT / VILT sessions
- f. Coordinate disciplined participation of the students
- g. Shall jointly monitor and review program milestones along with the COMPANY
- h. Shall facilitate participation of the candidates for activities of the program
- i. Provide access to the representatives from the COMPANY who are visiting the INSTITUTION
- j. Provide boarding and lodging for the trainers at the cost of the INSTITUTION for conducting the classroom trainings
- k. **Branding, Communication, Publicity and Trademark of the program**
  1. INSTITUTION agrees that the logos which will be shared by NASSCOM Foundation only will be implemented wherever required under this agreement.
  2. COMPANY will work with INSTITUTION to ensure that all communication is agreed upon ahead of time as per agreed guidelines.
  3. INSTITUTION agrees that any content, LMS, app, source code developed under this Agreement will be owned by the COMPANY. Appropriate branding will be done with consent and prior approval.





4. INSTITUTION shall not without the prior written consent of the COMPANY:
- i. Take any photograph or video of the beneficiaries etc. for use in any merchandising publicity or advertising;
  - ii. Publish alone or in conjunction with any person any article, photograph, testimonials of the beneficiaries or other illustration either in social media or print or any other mode;
  - iii. Impart to any publication, journal or newspaper or any radio or television programme or any online platform any information in relation to this Agreement.
  - iv. Release any press statements or other publicity, including videos, testimonials, case studies of the beneficiaries in relation to the Agreement or the transactions contemplated by this Agreement.

**COMPANY shall**

- l. Provide training calendar in agreement with the INSTITUTION
- m. Provide trainings to the candidates in the modes of ILT/Platform/vILT modes in the ratio of 40% / 40% /20% – Refer to annexure-I
- n. Deploy trainers in the ratio of 1:100 candidates, and as acceptable to the INSTITUTION
- o. Provide training links and access to the training collateral, and coding platform as necessary
- p. Provide 60% placements to the eligible and certified candidates
- q. Organizing job melas /recruitment drives as appropriate
- r. Create, maintain, and manage a comprehensive placement planner and tracker.
- s. Support candidates to create student profiles, resumes, CVs, and Covering letters.

**2. Term:**

This agreement shall be effective from the commencement date mentioned above and will be effective for a period by which time the complete payment is made by the institution, unless terminated earlier as per Clause 4 of this agreement.

**3. Payment Terms:**

**4. Termination:**

- a. This agreement shall terminate on the completion of term except for the clauses specifically mentioned below at 4b,4c and 4d.
- b. COMPANY&INSTITUTION may terminate this Agreement in the event of material breach of one's scope of work and such breach is not cured within thirty (30) days of written notice to the other of such breach.
- c. The COMPANY may terminate this Agreement for its sole convenience by giving thirty (30) days advance notice in writing/e-mail to the INSTITUTION. In such event INSTITUTION shall cease work immediately after receiving notice from the COMPANY unless otherwise advised by the COMPANY.

**5. Dispute Resolution:**

- a. This agreement shall be governed according to the Indian laws and each Party shall submit to the jurisdiction of the Courts at Hyderabad, Telangana, India.





- b. Any and all differences and disputes whatsoever arising between the Parties concerning the interpretation or implementation of this Agreement or in relation to the subject matter contained in this Agreement shall, in the first instance, be resolved mutually between the Parties and in the event of non-resolution, the matter shall be referred to arbitration.
- c. Arbitration proceedings shall be held in Hyderabad in accordance with the Arbitration and Conciliation Act, 1996 and procedures established for the purposes of regulating and determining matters relating to or arising from arbitration. Both the Parties shall mutually appoint one arbitrator failing which the dispute shall be decided by an arbitration panel consisting of 3 arbitrators. Each Party shall appoint one arbitrator and both the arbitrators so appointed shall appoint a third arbitrator, who shall preside over the arbitration proceedings. Any decision, determination or award of the Arbitrator/s shall be binding on the Parties. Unless otherwise decided by the arbitrator/s, the cost of arbitration shall be shared by the Parties in equal proportion.

#### 6. Indemnity:

6.1 The COMPANY shall, fully indemnify, defend, and hold harmless the INSTITUTION and its officers, Directors, employees, representatives, agents, respective directors, and assigns from and against any liability or any other loss, damage, whether incidental or consequential, that may occur, arising from or relating to:

- a. A breach, by the COMPANY of any of the terms, conditions, covenants, representations, undertakings, obligations, deficiencies, warranties, and compliance of applicable laws under this Agreement.
- b. The acts, significant errors, misrepresentations, willful misconduct or negligence of the COMPANY, its employees, in performance of its obligations under this Agreement.
- c. Termination of the agreement without giving sufficient notice as defined in clause 6 and particularly when the batches for training are scheduled.

Similarly, the INSTITUTION shall indemnify the COMPANY and its officers, Directors, employees, representatives, agents, respective directors, and assigns from and against any liability or any other loss, damage, whether incidental or consequential, that may occur, arising from or relating to:

- a. The acts, significant errors, misrepresentations, willful misconduct or negligence of the INSTITUTION, its employees, in performance of its obligations under this Agreement.
- b. A breach, by the INSTITUTION of any of the terms, conditions, covenants, representations, undertakings, obligations, deficiencies, warranties, and compliance of applicable laws under this Agreement.

#### 7. Confidentiality and use restriction:

- a. No information either disclosed by the INSTITUTION or acquired through any other means or known incidentally by the COMPANY, either marked confidential or not, shall not be shared or





used by the COMPANY or any other third party through the COMPANY, without prior written approval from the authorized signatory of the INSTITUTION.

- b. Information means: financial data, data (Includes all sources and object code if any), know-how, trade secrets, designs, plans, reports, customer and supplier lists, pricing information, marketing techniques, material related to business activities, manufacturing, design, development, or products acquired through the expenditure of time, effort and money, of a technical and business nature - business plans, content, market information, drawings, sketches, samples, devices, flow charts, compiled computer programs, algorithms, software source codes, firmware source codes, hardware, methods, processes, procedures, specifications, bills of materials, parts lists, descriptions or customer lists, description and data of participants, results of research, equipment, software, designs, samples, technology, technical, documentation, product or service specifications or strategies, marketing plans, pricing information, financial information, information related to existing, previous and potential suppliers, customers, contracts and products, inventions, unreleased software applications, methodologies and other know-how, drawings, photographs models, mock-ups, and design and performance specifications, production volumes, and production schedules which are owned, controlled or possessed by Company respectively whether provided in tangible form, by electronic media, by visual display or orally,

#### 8. Compliance with Applicable Laws:

Both parties ensure that all work performed within the scope of their work under this Agreement shall comply with all applicable Indian laws and regulations.

COMPANY shall be responsible to provide all required documentation and perform all necessary compliances under the GST Act to make Company eligible to claim the input tax credit of GST. In case Company is unable to claim the input tax credit due to but not limited to Service Provider failure to declare the correct information on the invoice and upload the same under GST portal viz. the amount, the place of supply, rate of tax etc., then the amount pertaining to the GST paid by COMPANY shall be refunded by Service Provider and the amount shall be recovered from Service Provider, as the case may be.

#### 9. Severability:

If any of the provisions of this Agreement are declared to be invalid or legally unenforceable, such provisions shall be severed from this Agreement and the other provisions hereof shall remain in full force and effect.

#### 10. Miscellaneous:

- a. This Agreement can be modified, amended, altered, extended based on mutual agreement in writing by both the parties and such amendment shall form part of this agreement from the date of its effect.
- b. Any notice, request or consent required or permitted to be given or made pursuant to this Agreement shall be in writing. Any such notice, request or consent shall be deemed to have been given or made when delivered in person to an authorized representative of the Party to whom the communication is addressed, or when sent by trackable courier, authorized e-mail, or fax to such Party at the address specified-in above.





- c. Nothing contained herein shall be construed as establishing a relation of master and servant or of principal and agent as between the INSTITUTION and the COMPANY
- d. No failure or delay by any Party in exercising any right, power or privilege hereunder shall operate as a waiver thereof nor shall any single or partial exercise of any other right, power, or privilege. The rights and remedies herein provided shall be cumulative and not exclusive of any rights or remedies provided by law.
- e. The captions herein are included for convenience of reference only and shall be ignored in the construction or interpretation hereof.
- f. This Agreement constitutes the entire agreement between the Parties with respect to the subject matter hereof and supersedes all prior written agreements, understandings, and negotiations, both written and oral, between the Parties with respect to the subject matter of this Agreement. No representation, inducement, promise, understanding, condition or warranty not set forth herein has been made or relied upon by any Party hereto

IN WITNESS WHEREOF the Parties hereto have hereunto set and subscribed their respective hands and seal at the day, month and year first herein above written.

#### 11. Registration & Certification

- g. a. D101 Google form Registration for all the years of Grads & Under Grads
- h. b. Baseline Assessment Survey Tool for Final Year Students of Grads & Under Grads
- i. Mgmt should support and ensure in registration & Certifications of D101 & BPM/IT Service Desk Assessment

For Mouktik Consultancy Services Private Limited



Name: Mr. Muralidharr

Designation: Nasscom Engagements - Program Director



For <<INSTITUTION>>

MMCC



Name: Dr. Devidas Golhar

Designation: Principal.

Principal

Marathwada Mitra Mandal's  
College of Commerce  
Pune-411 004





Tax Invoice Cum Delivery Challan  
Samples

(ORIGINAL FOR RECIPIENT)

# 492950286

10182/

<b>PRABHATH SOLUTIONS</b> No.3/118,2nd Floor,9th Main Road, Jayanagar,3rd Block, Bengaluru - 560011 CIN: U51506KA2006PTCO38158 Ph: 080-41210132 / 9845171010 GSTIN/UIN: 29AONPS2780J1Z5 State Name : Karnataka, Code : 29 E-Mail : mahendra@eprabhat.com	Invoice No.	Dated
	10471	20-Mar-23
Consignee (Ship to) <b>NASSCOM Foundation</b> Marathwada Mitra Mandals College of Commerce 202/A, Deccan Gymkhana , Pune-411004 Ph: 9154758366 State Name : Maharashtra, Code : 27	Delivery Note	Mode/Terms of Payment
	10471	Transfer
Buyer (Bill to) <b>NASSCOM Foundation</b> A1-125, Safdurjung Enclave, Opp Ambeince Public School , New Delhi-110029 GSTIN/UIN : 07AAATN4866D1ZK State Name : Delhi, Code : 07	Reference No. & Date.	Other References
	10471 dt. 20-Mar-23	
	Buyer's Order No.	Dated
	NF/2022-23/018	14-Mar-23
	Dispatch Doc No.	Delivery Note Date
		20-Mar-23
	Dispatched through	Destination
	Gati Kwe	Pune
Terms of Delivery		

P  
R  
A  
B  
H  
A  
T  
H  
  
S  
O  
L  
U  
T  
I  
O  
N  
S

Sl No.	Description of Goods	HSN/SAC	Quantity	Rate	per	Amount
1	HP Slim Desktop S01-PF2888in Intel i3 , 8gb Ram, 512GB SSD Window 11 + MS Office 3 Year Warranty From Hp Direct	84715000	20 nos	43,800.00	nos	8,76,000.00
2	HP LED Monitor 19.5"V20 HD+	85285200	20 nos			
3	UPS 600V Zebronic ZEB-U775	8504400	20 nos	1,700.00	nos	34,000.00
4	W200 Webcam HP	85258010	20 nos	1,550.00	nos	31,000.00
5	HP Headphone with Microphone B4B09PA	84733099	20 nos	725.00	nos	14,500.00
6	Acer X1226AH DLP Projector	85286200	1 nos	31,580.00	nos	31,580.00
7	Logic 84" 4X6 Wall Mount Insta Lock Screen	90106000	2 nos	3,200.00	nos	6,400.00
8	Ahuja PA Active Speakers XPA 1510 DP	85182200	1 nos	17,500.00	nos	17,500.00
9	Ahuja Wireless Mic	85181000	2 nos	3,550.00	nos	7,100.00
10	Ahuja Collar Mic	85181000	1 nos	3,950.00	nos	3,950.00
11	IP Camera	84713010	2 nos	4,200.00	nos	8,400.00
12	Interactice Digital White Board	85171010	1 nos	18,500.00	nos	18,500.00
						10,48,930.00
Less : <b>Output IGST Round Off</b>						1,88,807.40 (-).040
Total			110 nos			₹ 12,37,737.00

Amount Chargeable (in words) <b>INR Twelve Lakh Thirty Seven Thousand Seven Hundred Thirty Seven Only</b>	Company's Bank Details A/c Holder's Name: PRABHATH SOLUTIONS Bank Name : Axis Bank A/c No. : 917020066256189 Branch & IFS Code: Jayanagar & UTIB0003567 SWIFT Code :
Declaration Subject to Bangalore Jurisdiction Hp Toll Free No's - Desktop / Laptop- 1800 258 7170 Hp Toll Free Nos - Printers - 1800 425 4999	for PRABHATH SOLUTIONS  Authorised Signatory

SUBJECT TO BANGALORE JURISDICTION

This is a Computer Generated Invoice





Tax Invoice Cum Delivery Challan  
Samples  
(Tax Analysis)

(ORIGINAL FOR RECIPIENT)

Invoice No. 10471

Dated 20-Mar-23

**PRABHATH SOLUTIONS**

No.3/118,2nd Floor,9th Main Road,  
Jayanagar,3rd Block,  
Bengaluru - 560011

CIN: U51506KA2006PTCO38158

Ph: 080-41210132 / 9845171010

GSTIN/UIN: 29AONPS2780J1Z5

State Name : Karnataka, Code : 29

E-Mail : mahendra@eprabhat.com

Party : **NASSCOM Foundation**

A1-125, Safdurjung Enclave, Opp Ambeince Public

School , New Delhi-110029

GSTIN/UIN : 07AAATN4866D1ZK

State Name : Delhi, Code : 07

HSN/SAC	Taxable Value	Integrated Tax		Total Tax Amount
		Rate	Amount	
8470000	8,76,000.00	18%	1,57,680.00	1,57,680.00
8520200		18%		
8504400	34,000.00	18%	6,120.00	6,120.00
85258010	31,000.00	18%	5,580.00	5,580.00
84733099	14,500.00	18%	2,610.00	2,610.00
85286200	31,580.00	18%	5,684.40	5,684.40
90106000	6,400.00	18%	1,152.00	1,152.00
85182200	17,500.00	18%	3,150.00	3,150.00
85181000	11,050.00	18%	1,989.00	1,989.00
84713010	8,400.00	18%	1,512.00	1,512.00
85171010	18,500.00	18%	3,330.00	3,330.00
<b>Total</b>	<b>10,48,930.00</b>		<b>1,88,807.40</b>	<b>1,88,807.40</b>

Tax Amount (in words) : **INR One Lakh Eighty Eight Thousand Eight Hundred Seven and Forty paise Only**

for PRABHATH SOLUTIONS



Authorised Signatory

PRABHATH SOLUTIONS



#493190816

648/-

Prabhat

MURALIDHARA  
Marathwada Mitra Mandal's College of Commerce  
202/A, Deccan Gymkhana, Pune - 411004, Maharashtra  
Ph: 9154758366

From,  
Prabhath Solutions  
No.3/118, 3<sup>rd</sup> Block, 9<sup>th</sup> Main  
Jayanagar, Bangalore-560011  
Ph: 9686864404 / 9845171010

To Whom So Ever it May Concern

The Ahuja Speaker is Sent as a Donation Purpose and Not for any Commercial use

The Approx Value for the Speaker is Rs.10000/-

Thanking You  
Yours Faithfully  
For Prabhath Solutions

  
Auth Sign

P  
R  
A  
B  
H  
A  
T  
H  
  
S  
O  
L  
U  
T  
I  
O  
N  
S





# Foundation for Make It Happen Center for Invention, Innovation & Incubation (MMCIII)

A section 8 Company, Registration Number - 121234, CIN - U80301PN2020NPL194869

(Joint Collaboration of Tata Technologies Ltd., Science & Technology Park and Marathwada Mitramandal, Pune)

Ref. No. : MMM / MMCIII / 2020-21 / Cent / 03

Date : 25.07.2022

## To whomsoever it may concern

Marathwada Mitramandal's College of Commerce (MMCC) have MOU with Foundation for MakeItHappen Center for Invention, Innovation and Incubation (MMCIII) on date 9<sup>th</sup> July 2021.

Highlighted points of the MOU for AY 2021-2022 are:

- 1) To bridge the gap between Institute and Industry.
- (2) To Motivate and guide students those who are interested to startup their business/Startups.
- (3) To provide industry level training to enhance the skillset and overall development of the students.
- (4) MMCIII center have 35 startups in different domains, so these startups required some interns as well as an employee; so, here MMCC students will get direct benefit of working with company as well as employment in companies.

This is a good initiative taken by the Marathwada Mitramandal's College of Commerce (MMCC). Hope this MOU will help them to move forward up to some extent.

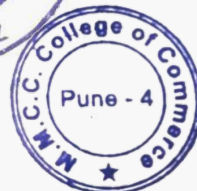

*Dr. C. R. Talathi*

Dr. C. R. Talathi

CEO, FMCIII



Ref. No. : mmm / mmciii / 2022-23 / cert / 02

Date : 25.07.2022

## To whomsoever it may concern

Marathwada Mitramandal's College of Commerce (MMCC) had MOU with Foundation for MakeItHappen Center for Invention, Innovation and Incubation (MMCIII) on date 9<sup>th</sup> July 2021.

Following activities carried out in AY 2022-23:

- 1) 15 days training on Additive Manufacturing and Reverse Engineering conducted from date 1<sup>st</sup> to 15<sup>th</sup> of June 2022 for 12 Students.
- 2) 7 days training on Additive Manufacturing and Reverse Engineering conducted from date 6<sup>th</sup> to 10<sup>th</sup> of July 2022 for 18 students.
- 3) Also, some students completed internships through MMCIII.

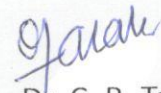

Dr. C. R. Talathi

CEO, FMCIII





“येथे बहुतांचे हित”

**Welfare of Masses**

# **Information and Communication Technology (ICT) Policy**

Marathwada Mitra Mandal's College of Commerce (MMCC)

202/A Deccan Gymkhana, Pune 411004



Revised for AY 2022-23



## Objectives of ICT Policy.

- The Information and Communication Technology (ICT) applications cover the areas-teaching-learning, student evaluation, student data management networking and quality assurance.
- As an ongoing process, ICT applications shall take note of the rapid pace of technology changes.
- ICT policy management shall be integrated with the overall institutional development plan.
- ICT system management must ensure integrity, security and legitimate applications of ICT.

## ICT resources covered by policy.

- Desktop computers, laptops and terminals.
- Peripherals e.g., printers, scanners and multimedia devices like web camera, speakers, PA system.
- Mobile devices e.g., smartphones and tablets using college provided Wi-fi devices.
- Network switch wired, wireless, dialup and/or internet connections.
- Internet services e.g., world wide web, blogs and wikis.
- G Suite for Education, social networking or collaboration services such as blogs, chats, MMCC YouTube channel and forums.
- Application software, services and databases.

## Area of ICT applications

### 1. Admissions:

- College publishes admission related information over the website through an information brochure for better reach and visibility.
- College provides an online registration facility for prospective students through ERP.

### 2. Teaching and Learning:

- College has a G Suite for education (Basic plan). ICT enabled teaching-learning encompasses use of features of Google classroom as part of G Suite for Education.
- Students have access to the facility using mmcc.edu.in Email Id. The Email Ids are created using the nomenclature –
  - Student First Name
  - Year
  - Program Name
  - Roll Number
- College encourages teachers to develop digital learning resources of their own. They post learning resources on Classroom.
- Online lecture attendance through google id is compulsory.



### 3. Student Evaluation

- College creates online systems for internal assessment through Google Classroom by publishing quiz, assignments, etc. that have evaluation parameters and its weightage.
- The College encourages teachers to use an online evaluation system.
- The teachers are encouraged to create question banks and share them through repositories.

### 4. Unacceptable uses of ICT resources

- Attempt to access computers for which the concerned individual is not authorized.
- Unauthorized access to another user's files.
- Use of pen drive without permission.
- Deliberate unauthorized access to networked resources local or remote.

### 5. Student Online Activities

- Students participate using mmcc.edu.in email id in curricular /Co-Curricular /Extra Curricular activities in online mode during exceptional times to ensure all round development.

### 6. Ensure content Validity

- Individual units at the department level are responsible for the Content on all of their Web pages.

Prepared by:



Prof. Vishakha Wagh  
Asst. Prof. BBA(CA)

Verified by:

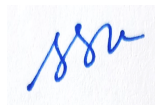

Dr. Swapna Kolhatkar  
IQAC Coordinator

Approved by:



Dr. Devidas Golhar  
Principal







MARATHWADA MITRA MANDAL'S  
COLLEGE OF COMMERCE

Affiliated to Savitribai Phule Pune University, Re-Accredited by NAAC with "A"  
Grade

ISO 9001:2015 Certified, Awarded as Best College by Savitribai Phule Pune  
University

202/A, Deccan Gymkhana, Pune – 411004

principal@mmcc.edu.in, enquiry@mmcc.edu.in, www.mmcc.edu.in

Date:-30/04/2023

**Report On  
Unnat Bharat Abhiyan, MMCC**

Unnat Bharat Abhiyan is a significant initiative of the Government of India aimed at driving rural development through the collaboration of higher educational institutions and rural communities. MMCC, with its vision of promoting quality education and sustainable development, has taken part in this flagship program by adopting five villages in Pune district: Ambi, Agalambe, Zalanwadi, Matalwadi, and Gorhe.

In these villages, a substantial portion of the community comprises residents, spinners, farmers, and farm laborers, with agriculture and complementary businesses being the primary sources of livelihood. While primary education facilities are available, there is a notable lack of interest in education among some backward communities, leading to a high dropout rate at the primary level. Many children are deprived of education as they accompany their parents to work in wage labor, rather than attending school.

To address these challenges, MMCC, as part of Unnat Bharat Abhiyan, has engaged with village stakeholders, including the Sarpanch, Gram Sevak, and other Panchayat members. The motto and objectives of the program were discussed with them, fostering an understanding of the shared goals. Additionally, a household survey was conducted to gain insights into the specific needs and requirements of the villages.

To improve healthcare in these rural areas, health camps were organized, providing primary health checkups for villagers and school children. Specific initiatives like breast cancer awareness and checkups were conducted in collaboration with hospitals.



Furthermore, to encourage education and mentorship opportunities in these villages, four-day value education programs were held at the schools. Through these initiatives, students benefited from enhanced educational facilities and were exposed to issues prevalent in rural areas. The student volunteers actively participated in all activities, witnessing positive role models and gaining insights into moral values, gender equality, respect, and the importance of education. The faculty members of MMCC have also played a crucial role in the success of the program, showing enthusiastic engagement and commitment to the cause.



**Students and faculties actively participating in various initiatives undertaken by MMCC**





Overall, Unnat Bharat Abhiyan has facilitated the transformational change in rural development processes in these adopted villages by leveraging the expertise of MMCC and other higher educational institutions. The collaborative efforts aim to accelerate sustainable growth and improve the overall well-being of rural communities in India.



Dr.Sandip Anpat  
Coordinator, UBA MMCC

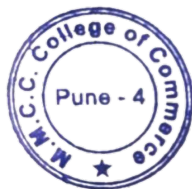

## HDFC BANK LTD

Account Number	: 50100106708433	Product Code	: 145-INSTITUTIONAL SAVINGS ACCOUNT
Customer Name	: MMMS COLLEGE OF COMMERCE NON GRANT AC	A/C Currency	: INR
Customer Id	: 62737749	Branch Code	: 149
A/C Open Date	: 12/06/2015	Branch Name	: KOTHRUD
Joint Holder	: None	Branch Address	: PLOT NO 58, 59
Joint Holder	: None		MAYUR COLONY
Address	: 302/A DECCAN GYMKHANA		KOTHRUD
	PUNE	City	: PUNE
City	: PUNE	Pin Code	: 411029
Pin Code	: 411004	State	: MAHARASHTRA
State	: MAHARASHTRA	Country	: India
Country	: INDIA	Branch Tel No	: 020-61606161
Res Tel No	:	MICR Code	: 411240009
Mobile No	: 919422000217	IFSC Code	: HDFC0000149
Nomination	: Not Registered		





18/06/22	ELOR OF COMPUTER SC BSC COMP-CMS26527229					
	NEFT Dr-UBIN0561134-PRATIK SANJAY KSHIRS	N169222004491284	18/06/22	3240.00		1754855.34
18/06/22	AGAR-KOTHRUD - PU-N169222004491284					
	NEFT Dr-BKID0000827-SHASHANK SUNIL SURVE	N169222004490851	18/06/22	12960.00	22,000	1741895.34
	-KOTHRUD - PU-N169222004490851					
18/06/22	NEFT Dr-KKBR0001755-BHAGWAT SHIVAJI GITE	N169222004485350	18/06/22	3240.00		1738655.34
	-KOTHRUD - PU-N169222004485350					
18/06/22	NEFT Dr-SBIN0012926-GAURAV KOTECHA-KOTHR	000000001240	18/06/22	2160.00		1736495.34
	UD - PU-N169222004468135					
18/06/22	NEFT Dr-MAHB0001355-SIDDHARTH KALE-KOTHR	N169222004479577	18/06/22	5400.00		1731095.34
	UD - PU-N169222004479577					
20/06/22	NEFT Cr-ICIC0000018-ATOM Dyeizykn2007502	CMS2654968811	20/06/22		9400.00	1740495.34
	5 MARATHWADA MITRA MANDALS COL-MMMS BACH					
	ELOR OF COMPUTER SC BSC COMP-CMS26549688					
21/06/22	NEFT Cr-SBIN0004266-IRD IIT Delhi-MMMS C	SBIN222172088082	21/06/22		50000.00	1790495.34
	COLLEGE OF COMMERCE NON GRANT-SBIN2221720					
	88082					
	Balance C/F					1790495.34

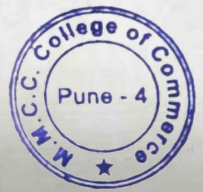



**GFR 12 - A**  
[[See Rule 238 (1)]]

Extra copy

**FORM OF UTILIZATION CERTIFICATE  
FOR AUTONOMOUS BODIES OF THE GRANTEE ORGANIZATION**

UTILIZATION CERTIFICATE FOR THE YEAR... 2022-23 [21/6/22 To 01/06/23] in respect  
of recurring/non-recurring  
GRANTS-IN-AID/SALARIES/CREATION OF CAPITAL ASSETS

- Name of the Scheme... Unnat Bharat Abhiyan
- Whether recurring or non-recurring grants... Non-Recurring Grants
- Grants position at the beginning of the Financial year
  - Cash in Hand/Bank - NIL
  - Unadjusted advances - 50,000
  - Total - 50,000
- Details of grants received, expenditure incurred and closing balances: (Actuals)

Unspent Balances of Grants received years [figure as at Sl. No. 3 (iii)]	Interest Earned thereon	Interest deposited back to the Government	Grant received during the year			Total Available funds (1+2-3+4)	Expenditure incurred	Closing Balances (5-6)
			Sanction No. (i)	Date (ii)	Amount (iii)			
1	2	3	4			5	6	7
<u>NIL</u>	<u>NIL</u>	<u>NIL</u>	<u>Sl. No. 46</u> <u>SBIN 222</u> <u>172088082</u>	<u>21/6/22</u>	<u>50,000</u>	<u>50,000</u>	<u>50,000</u>	<u>NIL</u>

Component wise utilization of grants:

Grant-in-aid- General	Grant-in-aid- Salary	Grant-in-aid-creation of capital assets	Total

Details of grants position at the end of the year

- Cash in Hand/Bank - NIL
- Unadjusted Advances - NIL
- Total - NIL



F&A KRISHNA RAWAS & ASSOCIATES  
CHARTERED ACCOUNTANTS  
Desai  
CA., DR. K.M. RAWAS  
Memb. No. 039675  
(M.Com., F.C.A., Ph.D.)

Win - 23035675139WVJ35146





**GENERAL FINANCIAL RULES 2017**  
 Ministry of Finance  
 Department of Expenditure

Certified that I have satisfied myself that the conditions on which grants were sanctioned have been duly fulfilled/are being fulfilled and that I have exercised following checks to see that the money has been actually utilized for the purpose for which it was sanctioned:

- (i) The main accounts and other subsidiary accounts and registers (including assets registers) are maintained as prescribed in the relevant Act/Rules/Standing instructions (mention the Act/Rules) and have been duly audited by designated auditors. The figures depicted above tally with the audited figures mentioned in financial statements/accounts.
- (ii) There exist internal controls for safeguarding public funds/assets, watching outcomes and achievements of physical targets against the financial inputs, ensuring quality in asset creation etc. & the periodic evaluation of internal controls is exercised to ensure their effectiveness.
- (iii) To the best of our knowledge and belief, no transactions have been entered that are in violation of relevant Act/Rules/standing instructions and scheme guidelines.
- (iv) The responsibilities among the key functionaries for execution of the scheme have been assigned in clear terms and are not general in nature.
- (v) The benefits were extended to the intended beneficiaries and only such areas/districts were covered where the scheme was intended to operate.
- (vi) The expenditure on various components of the scheme was in the proportions authorized as per the scheme guidelines and terms and conditions of the grants-in-aid.
- (vii) It has been ensured that the physical and financial performance under... VBI... (name of the scheme has been according to the requirements, as prescribed in the guidelines issued by Govt. of India and the performance/targets achieved statement for the year to which the utilization of the fund resulted in outcomes given at Annexure – I duly enclosed.
- (viii) The utilization of the fund resulted in outcomes given at Annexure – II duly enclosed (to be formulated by the Ministry/Department concerned as per their requirements/specifications.)
- (ix) Details of various schemes executed by the agency through grants-in-aid received from the same Ministry or from other Ministries is enclosed at Annexure –II (to be formulated by the Ministry/Department concerned as per their requirements/specifications).

Date: 13/01/23

Place: PUNE M.M.C.C.

Signature   
 Name: Mrs. Shilpa Lad  
 Accountant  
 Marathwada Mitra Mandal's  
 Chief Financial Officer  
 College of Commerce  
 (Head of the Finance)  
 Pune-411 004

Signature   
 Name: Dr. Devidas G. Galhar  
 PRINCIPAL  
 Marathwada Mitra Mandal's  
 Head of the Organisation  
 College of Commerce  
 Pune-411 004

(Strike out inapplicable terms)



F&A KRISHNA RAWAS & ASSOCIATES  
 CHARTERED ACCOUNTANTS  
  
 CA., DR. K.M. RAWAS  
 Memb. No. 033675  
 (M.Com., F.C.A., Ph.D.)





उन्नत भारत अभियान  
राष्ट्रीय समन्वय संस्थान  
भारतीय प्रौद्योगिकी संस्थान दिल्ली  
हौज़ खास, नई दिल्ली-११००१६



**UNNAT BHARAT ABHIYAN**  
NATIONAL COORDINATING INSTITUTE  
**INDIAN INSTITUTE OF TECHNOLOGY DELHI**  
Hauz Khas, New Delhi - 110016  
Website : <http://unnat.iitd.ac.in>

**Prof. Virendra K. Vijay**  
National Coordinator, UBA  
Professor CRDT, IITD

Tel. : +91-11-2659 1121/1157 (O)  
Fax : +91-11-2659 1121  
Email : [unnatbharatabhiyaniitd@gmail.com](mailto:unnatbharatabhiyaniitd@gmail.com)  
[vkvijay@rdat.iitd.ac.in](mailto:vkvijay@rdat.iitd.ac.in)

Dear Sir/Madam,

Congratulations to all the Participating Institutions (PIs) selected under Unnat Bharat Abhiyan, a flagship program of Ministry of Human Resource Development (MHRD) Government of India through a challenge mode application. The Mission of Unnat Bharat Abhiyan is to enable participating higher educational institutions to work with the people of rural India in identifying development challenges and evolving appropriate solutions for accelerating sustainable growth. It also aims to create a virtuous cycle between society and an inclusive academic system by providing knowledge and practices for emerging professions and to upgrade the capabilities of both the public and the private sectors in responding to the development needs of rural India.

As per the programme, educational institutions is primarily to develop linkage with selective rural clusters (preferably of five villages), to get involved in the planning process and to promote the requisite S&T interventions to improvise and expedite the developmental efforts in those clusters. The approach is a departure from the grant oriented method and would see the participation and commitment of faculty and students in this endeavour.

We shall be processing release of Rs. 10000/- per village under the UBA program. The funds are mainly meant for assistance for awareness, Gram Panchayat Development Plan (GPDP) study, need assessment, and contingency expenditure. There are provision of Rs 1.0 lakh for technological intervention/ solution and Rs 0.50/- lakh for customization of a technological solution under the program. Which you can avail of afterwards by submitting proposals with ratification of the Gramsabha. A two-way channel between PIs and National Coordinating Institute (NCI) as well as Subject Expert Groups (SEGs) for project proposal submission and evaluation has been developed and functional on UBA portal. You can use your login credential for uploading proposals on UBA website '**FINANCIAL AIDS**'. The login credentials are same as your registration login credentials.

You are also requested to keep IIT Delhi, the National Coordinating Institute updated about your activities so that the same can be uploaded on the website of UBA.

**Regards and best wishes for your institution for contributing to India's development.**

With regards

Your Sincerely,







MARATHWADA MITRA MANDAL'S  
COLLEGE OF COMMERCE

Affiliated to Savitribai Phule Pune University, Re-Accredited by NAAC with "A" Grade  
ISO 9001:2015 Certified, Awarded as Best College by Savitribai Phule Pune University  
202/A, Deccan Gymkhana, Pune – 411004  
principal@mmcc.edu.in, enquiry@mmcc.edu.in, www.mmcc.edu.in

Date:-23/08/2023

**IIRS ISRO Nodal Center**

**Report on**

**Chandrayaan-3 Landing Event organized by Nodal Center**

**On 23rd August 2023**

IIRS ISRO MMCC Nodal Center organized a special event to commemorate the landing of Chandrayaan-3, India's third lunar exploration mission. The event aimed to celebrate India's accomplishments in space exploration and encourage students to pursue careers in STEM fields. It provided students with an opportunity to witness the historic moment of Chandrayaan-3's landing and engage in educational activities related to space exploration.

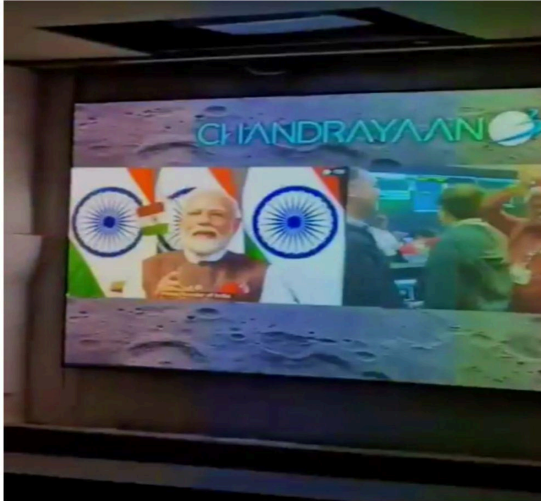

**MMCC**  
**ISRO Nodal Center**  
**Chandrayaan -3 Landing**  
**23 Aug. 2023**



**Students and faculties witnessing the historic moment of Chandrayaan-3's landing.**



#### Event Highlights:

**Live Broadcast of Landing:** A large screen was set up in the college auditorium to broadcast the live coverage of Chandrayaan-3's landing. Students gathered in the auditorium to witness the historic event unfold in real-time, experiencing the excitement of space exploration.

**Expert Views:** Eminent scientists and space experts provided online views on India's space missions, the significance of Chandrayaan-3, and the future of lunar exploration. Online talks aimed to educate students about the scientific objectives of the mission and its potential contributions to our understanding of the Moon.

**Interactive Sessions:** Interactive sessions were conducted to engage students in discussions about space exploration, lunar geology, and the challenges of landing on the Moon. Students had the opportunity to ask questions and interact with the experts, enhancing their understanding of space science.

#### Outcome:

The Chandrayaan-3 landing event was highly successful in engaging students and fostering interest in space exploration. It provided an enriching learning experience and inspired students to consider careers in STEM fields, particularly aerospace engineering, astronomy, and planetary science. The event also promoted scientific literacy and raised awareness about India's achievements in space research among the student community.

#### Conclusion:

The Chandrayaan-3 landing event organized by IIRS ISRO Nodal Center MMCC served as a platform for students to celebrate India's space achievements and explore the exciting field of space science and technology. By providing opportunities for learning, interaction, and inspiration, the event contributed to nurturing a new generation of scientists and engineers passionate about space exploration.



Dr.Sandip Anpat  
Coordinator, IIRS ISRO Nodal Center



Dr. Devidas Golhar  
Principal







“येथे बहुतांचे हित”

MARATHWADA MITRA MANDAL'S  
COLLEGE OF COMMERCE

Affiliated to Savitribai Phule Pune University, Re-Accredited by NAAC with “A” Grade  
ISO 9001:2015 Certified, Awarded as Best College by Savitribai Phule Pune University  
202/A, Deccan Gymkhana, Pune – 411004  
principal@mmcc.edu.in, enquiry@mmcc.edu.in, www.mmcc.edu.in

**12. PEHEL 2022 या उपक्रमात आपल्या MMCC NSS च्या स्वयंसेवकांचा सक्रियपणे सहभाग:\***

रविवार दि. 16 ऑक्टोबर 2022 रोजी आपल्या मराठवाडा मित्र मंडळ वाणिज्य महाविद्यालयाच्या राष्ट्रीय सेवा योजनेच्या विद्यार्थ्यांनी PEHEL 2022 (Plastic and E-waste Handling for Eco- friendly Lifestyle) या इ कचरा आणि प्लास्टिक कचरा संकलन व व्यवस्थापन आणि जाणीवजागृती उपक्रमात सक्रियपणे सहभाग घेतला.

सदर उपक्रम पुणे महानगरपालिका, आदर पूनावाला स्वच्छ शहर उपक्रम, जनवानी संस्था, कमिन्स इंडिया फाउंडेशन इत्यादी संस्थांच्या सहयोगाने सकाळी 8 ते दुपारी 2 या वेळेत राबविण्यात आला होता.

सदर उपक्रमाचे उद्घाटन चित्तरंजन वाटिका, शिवाजीनगर येथे पुणे महानगरपालिकेचे आयुक्त मा. श्री. विक्रम कुमार यांच्या हस्ते करण्यात आले. याप्रसंगी पुणे मनपाचे नवनियुक्त स्वच्छतादूत म्हणून सुप्रसिद्ध कवी, गीतकार आणि लेखक डॉ. सलील कुलकर्णी तसेच आंतरराष्ट्रीय कीर्तीच्या टेनिसपटू ऋतुजा भोसले उपस्थित होते.

महाविद्यालयातील विद्यार्थ्यांनी याप्रसंगी पर्यावरण संवर्धनाविषयी पथनाट्य सादर करून ई कचरा आणि प्लास्टिक कचरा संकलन आणि व्यवस्थापनाबाबत जाणीव जागृती केली. महाविद्यालयातील 48 विद्यार्थ्यांनी सदर उपक्रमात सक्रियपणे सहभाग नोंदविला.

पुणे मनपा आयुक्त श्री विक्रम कुमार आणि डॉ. सलील कुलकर्णी यांनी याबाबत विद्यार्थ्यांचे कौतुक केले तसेच तरुणाईच्या या पर्यावरण संवर्धनाच्या विधायक कार्यातील सहभागाबाबत आनंद व्यक्त केला.

महाविद्यालय स्तरावर प्राचार्य डॉ. देविदास गोल्हार, प्रा. एस. एम. एडके यांच्या मार्गदर्शनाखाली सदर उपक्रम यशस्वीपणे पार पडला. राष्ट्रीय सेवा योजना कार्यक्रम अधिकारी प्रा. प्रवीण कड, प्रा. सुशील गंगणे यांनी कार्यक्रमाचे नियोजन केले.





**E-waste and Plastic Waste Collection Mega Drive**







# MARATHWADA MITRA MANDAL'S COLLEGE OF COMMERCE

Affiliated to Savitribai Phule Pune University,  
Re-Accredited by NAAC with "A" Grade

## **REPORT ON ONE DAY WORKSHOP ON STEPS INVOLVED IN PREPARING A PROJECT REPORT**

**Date:14/10/2022**

On 13<sup>th</sup> October 2022, Department of Business Administration had organized a one day workshop on "Steps Involved in Preparing a Project Report." 77 students attended the workshop along with all the faculties.

The program started with the welcoming of the resource person for the day, Dr. Ashwini Kulkarni. The welcome address was given by Asst. Prof. Gurmeet Kaur Rajpal and the session was taken ahead by the resource person thereafter.

The workshop began with an overview of the purpose and significance of a project report. The workshop focused on identifying the essential components of a project report, including the executive summary, introduction, methodology, findings, conclusions, and recommendations. Emphasis was placed on the importance of each section in conveying the project's objectives and outcomes effectively.

The session concluded with addressing student's doubts. Vote of thanks was proposed by Dr. Kalpana Vaidya

Dr. Ashwini Kulkarni  
HOD

Dr. Devidas Golhar  
Principal





**MARATHWADA MITRA MANDAL'S  
COLLEGE OF COMMERCE**

Affiliated to Savitribai Phule Pune University, Re-Accredited by NAAC with "A" Grade  
ISO 9001:2015 Certified, Awarded as Best College by Savitribai Phule Pune University  
202 A, Deccan Gymkhana, Pune – 411004

[principal@mmcc.edu.in](mailto:principal@mmcc.edu.in), [enquiry@mmcc.edu.in](mailto:enquiry@mmcc.edu.in), [www.mmcc.edu.in](http://www.mmcc.edu.in)

---

**NOTICE**

**Date: 27-09-2022**

This is to inform all students of Department of Business Administration that our department organises Avishkar Poster Making Competition on 28<sup>th</sup> Sept 2022.

**Instructions for the competition:**

1. Participant's poster size should be 1 m X 1 m only.
2. Name of the participant should not be on the poster.
3. Name of guide/mentor should not be on the poster.
4. Name of departments or its constituent/affiliated colleges or a recognised institute should not be on the poster.
5. Only selected entries will be taken further for Zonal Level.
6. The judges decision will be final.

**Venue:** Auditorium Porch

**Date:** 28<sup>th</sup> Sept 2022

**Time:** 10 am to 11 am

Dr. Ashwini Kulkarni  
HOD

Dr. Devidas Golhar  
Principal







MARATHWADA MITRA MANDAL'S  
COLLEGE OF COMMERCE

Affiliated to Savitribai Phule Pune University, Re-Accredited by NAAC with "A" Grade  
ISO 9001:2008 Certified, Awarded as Best College by Savitribai Phule Pune University  
202 A, Deccan Gymkhana, Pune - 411004

principal@mmcc.edu.in, enquiry@mmcc.edu.in, www.mmcc.edu

DEPARTMENT OF BUSINESS ADMINISTRATION

JUDGE EVALUATION SHEET

DATE: 28-09-2022

Sr. No.	Name of the Participant	Subject Knowledge	Presentation	Total
1	Priyanka Kalyandre	7	4	11
2	Anjali A Yajurvedi	6	3	9
3	Harsha Budhani	5	3	8
4	Prishit Baldota	9	8	17
5	vedant Shirole	5	2	7
6	Rajlaxmi Iyer	6	3	9
7	Rushikesh Chikale	8	5	13
8	Shantam Awate	8	8	16
9	Rohan Patil	8	5	13
10	Aditya Gaikwad	4	2	6

1) Name of the Judge: Dr. Devidas Golhar

Sign:

2) Name of the Judge: Dr. Ashwini Kulkarni

Sign:





# MARATHWADA MITRA MANDAL'S COLLEGE OF COMMERCE

Affiliated to Savitribai Phule Pune University, Re-Accredited by NAAC with "A" Grade  
ISO 9001:2015 Certified, Awarded as Best College by Savitribai Phule Pune University  
202 A, Deccan Gymkhana, Pune – 411004

[principal@mmcc.edu.in](mailto:principal@mmcc.edu.in), [enquiry@mmcc.edu.in](mailto:enquiry@mmcc.edu.in), [www.mmcc.edu.in](http://www.mmcc.edu.in)

## REPORT ON AVISHKAR POSTER MAKING COMPETITION

Department of Business Administration has organised "AVISHKAR POSTER MAKING COMPETITION" on 29<sup>th</sup> Sep 2022, Thursday. Total 10 students participated in this competition from BBA and BBA-IB.

The following are the winners of the same:

1. Prishit Baldota – A analytical study on Financial Planning for Salaried employees and strategies for tax planning
2. Shantanu Awate – Financial Literacy amongst below poverty line.
3. Rushikesh Chikhale – An overview of OLX

Asst. Prof. Snehal Borkar organised the competition. Dr. Ashwini Kulkarni and Dr. Kalpna Vaidya judged the posters of the event. Principal Dr. Devidas Golhar sir and all faculties of senior college graced the occasion with their presence.

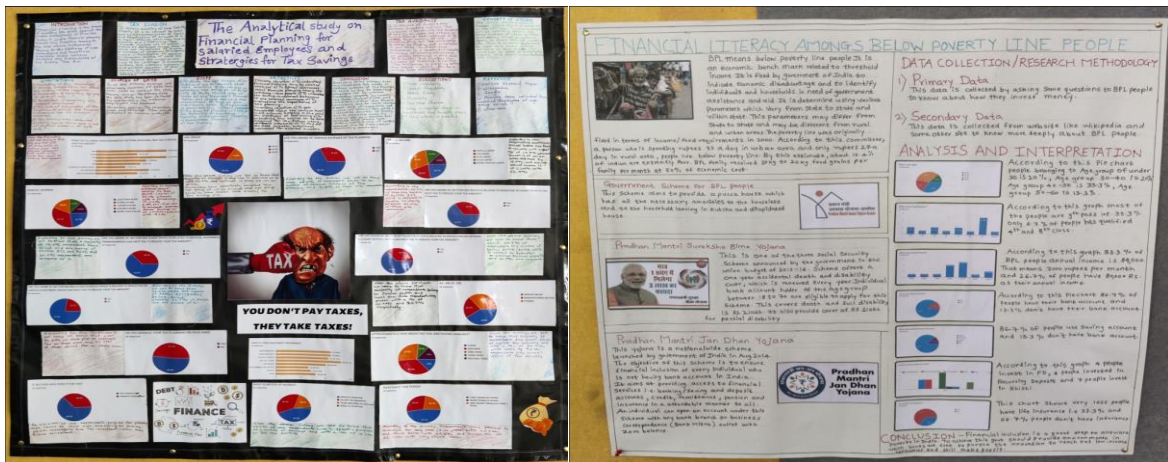

Dr. Ashwini Kulkarni  
HOD

Dr. Devidas Golhar  
Principal

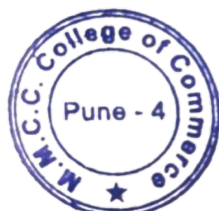



# MARATHWADA MITRA MANDAL'S COLLEGE OF COMMERCE

Affiliated to Savitribai Phule Pune University, Re-Accredited by NAAC with "A" Grade,  
ISO 9001:2008 Certified, Awarded as Best College by Savitribai Phule Pune University



MMCC/457/2022-23

**Dr. Devidas Golhar**  
Principal

Date: 28<sup>th</sup> September, 2022

To,  
The IQAC Cell,  
Savitribai Phule Pune University  
Pune - 411004.

Subject: Participation in Avishkar Poster Making Competition.

Respected Sir/ Madam,

With reference to the above subject, we would like to inform you that we are willing to participate in the Avishkar Poster Making Competition for A.Y. 2022-2023. In accordance with the same we have conducted a college level poster- making competition in the areas of commerce, management and law where 10 students have participated. The following are the winners

Sr.No	Position	Name of the student	Topic	Class
1.	1 <sup>st</sup> Prize	Mr. Prishit Baldota	A analytical study on financial planning for salaried employees and strategies for tax planning	TYBBA
2.	2 <sup>nd</sup> Prize	Mr. Shantanu Awate	Financial literacy amongst below poverty line people	TYBBA
3	3 <sup>rd</sup> Prize	Mr. Rushikesh Chikhale	An overview of OLX	TYBBA

Also, the results of the college level competition conducted dated 28<sup>th</sup> September 2022, Wednesday are attached for your ready reference. This is for your information and necessary action.

*Received*  
*Ju*  
*28/09/2022*

Regards,

  
Dr. Devidas Golhar  
Principal

Encl:

- ✓ Students' attendance
- ✓ Judges' score sheet
- ✓ Videos
- ✓ Geo- tagged photos
- ✓ A3 photocopies of winning posters



(54) Title of the invention : DIELECTRIC CONSTANT MEASUREMENT DIELECTRIC SPECTROSCOPY SENSOR

(51) International classification :G01N0027220000, A61B0005000000, G01R0035000000, A61M0005172000, G01N0027020000  
 (86) International Application No :NA  
 Filing Date :NA  
 (87) International Publication No :NA  
 (61) Patent of Addition to Application Number :NA  
 Filing Date :NA  
 (62) Divisional to Application Number :NA  
 Filing Date :NA

(71)Name of Applicant :  
 1)Dr. Sayad Shafiyuddin B.  
 Address of Applicant :Milliya Arts, Science and Management Science College, Beed Killa Maidan, Beed, Maharashtra, India 431122 -----  
 2)Dr. Sandip Anpat  
 3)Dr. Shaikh Mudassar  
 4)Mr. Gaus Mohiuddin Sayyad  
 5)Dr. Ashok Dongare  
 6)Dr. Mangesh Kolapkar  
 7)Dr. Santosh Dubal  
 8)Dr. Patil Gangadhar  
 9)Aruna P. Maharolkar  
 Name of Applicant : NA  
 Address of Applicant : NA  
 (72)Name of Inventor :  
 1)Dr. Sayad Shafiyuddin B.  
 Address of Applicant :Milliya Arts, Science and Management Science College, Beed Killa Maidan, Beed, Maharashtra, India 431122 -----  
 2)Dr. Sandip Anpat  
 Address of Applicant :Marathwada Mitra Mandal's College of Commerce, Pune 202/A, Deccan Gymkhana, Pune, Maharashtra, India, -411004, pune -----  
 3)Dr. Shaikh Mudassar  
 Address of Applicant :New Arts Commerce and Science College, Ahmendagar (Autonomous) Laltaki Road, Ahmednagar, Maharashtra, India, 414001 -----  
 4)Mr. Gaus Mohiuddin Sayyad  
 Address of Applicant :MGM's Jawaharlal Nehru Engineering College, Aurangabad N-6, CIDCO, Aurangabad, Maharashtra, India, 431003 -----  
 5)Dr. Ashok Dongare  
 Address of Applicant :Vasantdada Patil Arts, Commerce and Science College Patoda Court Road Patoda, Tq. Patoda, District Beed, Maharashtra, India, 414204 -----  
 6)Dr. Mangesh Kolapkar  
 Address of Applicant :Vidyapratishthan's Arts, Science and Commerce College, Baramati Vidyanageri, Bhigwan Road, Baramati, Dist-Pune, Maharashtra, India, 413133 -----  
 7)Dr. Santosh Dubal  
 Address of Applicant :Balbhim Arts, Science and Commerce College, Beed Balbhim Chowk, Killa Maidan Beed, Maharashtra, India, 431122 -----  
 8)Dr. Patil Gangadhar  
 Address of Applicant :KRT Arts, BH Commerce & AM Science (KTHM) College, Nashik Gangapur Road, Shivajinagar, Nashik-422002 -----  
 9)Aruna P. Maharolkar  
 Address of Applicant :Maharashtra Institute of Technology MIT, Beed by paas road Aurangabd 431004 aruna\_physics@rediffmail.com 9326222790 Aurangabad -----

(57) Abstract :

The present disclosure relates to a dielectric spectroscopy sensor system for measuring liquid , solids dielectric constant, wherein a microcontroller based system is employed. With the help of a function generator that produces the appropriate frequency, the suggested system uses the microcontroller's features to measure the dielectric constant of liquids. The function generator XR2206, the P89v51RD2 microprocessor with LCD display, and a specially developed dielectric cell are the components of the hardware design of the created dielectric spectroscopic sensor for detecting the dielectric constant of liquid using a microcontroller. The developed sensor system is cost-effective, lightweight, and simple to use without any programming expertise.

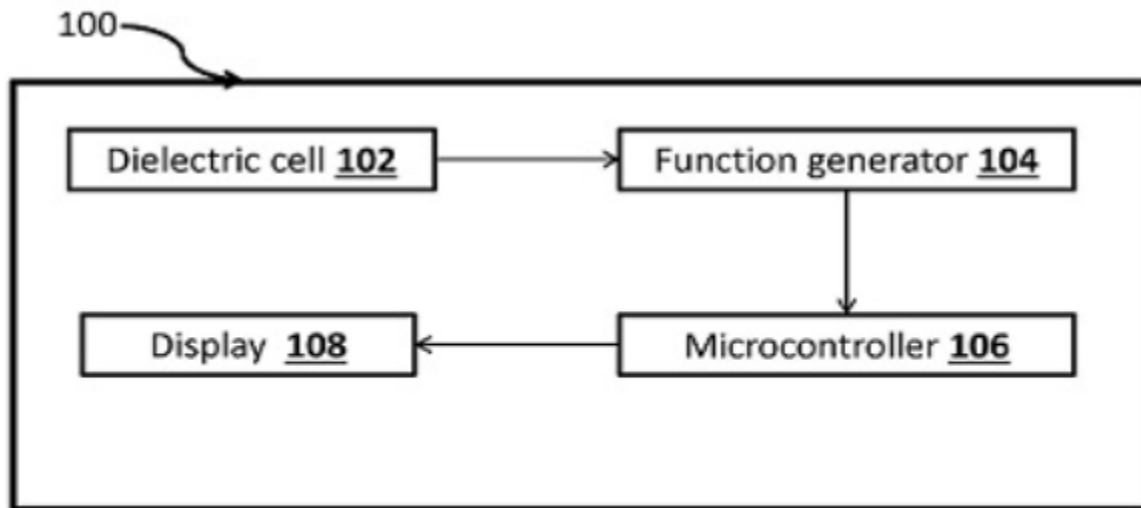

Figure 1

No. of Pages : 13 No. of Claims : 9





(54) Title of the invention : HUMIDITY, SOIL MOISTURE AND TEMPERATURE IN POLYHOUSE MEASUREMENT AN EMBEDDED SYSTEM

(51) International classification :A01G 251600, A01G 270000, G01N 272200, G01N 332400, G08B 212000  
 (86) International Application No :NA  
 Filing Date :NA  
 (87) International Publication No :NA  
 (61) Patent of Addition to Application Number :NA  
 Filing Date :NA  
 (62) Divisional to Application Number :NA  
 Filing Date :NA

(71)Name of Applicant :  
**1)Dr. Sayyad Shaffiyoddin B.**  
 Address of Applicant :Milliya Arts, Science and Management Science College, Beed Killa Maidan, Beed, Maharashtra, India 431122 -----  
**2)Dr. Mangesh Kolapkar**  
**3)Jayant Kolapkar**  
**4)Gaus Mohiuddin Sayyad**  
**5)Dr. Sandip Anpat**  
**6)Dr. Ashok Dongare**  
**7)Dr. Shaikh Mudassar**  
**8)Dr. Santosh Dubal**  
**9)Dr. Patil Gopinath**  
**10)Dr. Aruna P. Maharolkar**  
 Name of Applicant : NA  
 Address of Applicant : NA  
 (72)Name of Inventor :  
**1)Dr. Sayyad Shaffiyoddin B.**  
 Address of Applicant :Milliya Arts, Science and Management Science College, Beed Killa Maidan, Beed, Maharashtra, India 431122 -----  
**2)Dr. Mangesh Kolapkar**  
 Address of Applicant :Vidyapratishthan's Arts, Science and Commerce College, Baramati Vidyanageri, Bhigwan Road, Baramati. Dist-Pune, Maharashtra, India, 413133 baramati -----  
**3)Jayant Kolapkar**  
 Address of Applicant :Indian Institute of Information Technology Kottayam Kerala 686635 -----  
**4)Gaus Mohiuddin Sayyad**  
 Address of Applicant :MGM's Jawaharlal Nehru Engineering College, Aurangabad N-6, CIDCO, Aurangabad, Maharashtra, India, 431003 -----  
**5)Dr. Sandip Anpat**  
 Address of Applicant :Marathwada Mitra Mandal's College of Commerce, Pune 202/A, Deccan Gymkhana, Pune, Maharashtra, India, -411004, -----  
**6)Dr. Ashok Dongare**  
 Address of Applicant :Vasantdada Patil Arts, Commerce and Science College Patoda Court Road Patoda, Tq. Patoda, District Beed. Maharashtra, India. 414204 -----  
**7)Dr. Shaikh Mudassar**  
 Address of Applicant :New Arts Commerce and Science College, Ahmendagar (Autonomous) Laltaki Road, Ahmednagar, Maharashtra, India, 414001 -----  
**8)Dr. Santosh Dubal**  
 Address of Applicant :Balbhim Arts, Science and Commerce College, Beed Balbhim Chowk, Killa Maidan Beed, Maharashtra, India, 431122 -----  
**9)Dr. Patil Gopinath**  
 Address of Applicant :KRT Arts, BH Commerce & AM Science ( KTHM) College, Nashik Gangapur Road, Shivajinagar, Nashik-422002 -----  
**10)Dr. Aruna P. Maharolkar**  
 Address of Applicant :Maharashtra Institute of Technology MIT, Beed by paas road Aurangabad 431004 aruna\_physics@rediffmail.com 9326222790 Aurangabad -----

(57) Abstract :  
 The system comprises a plurality of sensors (102) for measuring a plurality of parameters such as the humidity, the soil moisture and temperature in the polyhouse; a plurality of signal conditioning device (104) connected to the plurality of sensors for optimizing captured analog signals obtained from each of the plurality of sensors (102); an analog multiplexer (106) connected to each of the plurality of signal conditioning device (104) for data acquisition; a controller (110) connected to the converter (108) for generating a plurality of instructions to control the analog multiplexer (106), wherein the humidity data is collected based on a first instruction, the soil moisture data is collected based on a second instruction and the temperature data is collected based on a third instruction; and a display and a control module (112) connected to the controller (110) for displaying the plurality of parameters sensed by the plurality of sensors (102)

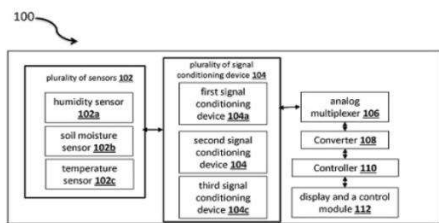
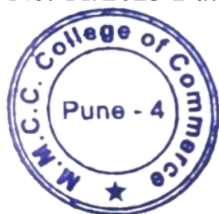

Figure 1

No. of Pages : 28 No. of Claims : 10



## Patents:

1. Indian Patent published titled 'A Rural Development Tracking Systems based on Foresight Methodologies and method thereof' vide application no. 202121050897 dated 6 November 2021
2. Indian Patent published titled 'A dynamic User Interface in a Cloud Network using deep Learning Model' vide application no. 202141034584 dated 6 August 2021.
3. Indian Patent Publication titled "A Traceable Healthcare Analytics Management System and Method Thereof" Application Id: 202221026076, Intellectual Property (IPR) India (2022) <https://ipindiaservices.gov.in/PatentSearch/PatentSearch/ViewApplicationStatus>.

